



# STATIC DYNAMIC COMPLETE



## MDA 8000HD



350 MHz - 2 GHz  
Motor Drive Analyzer

-  **Static** power analysis - like a dedicated power analyzer
-  **Dynamic** power analysis - capture more information
-  **Complete** test coverage - control system, power section, motor

# Static



## Like a Power Analyzer Instrument

- Numerics table mean value display
- Accuracy within 1% of a dedicated power analyzer
- Harmonic order calculations and vector displays

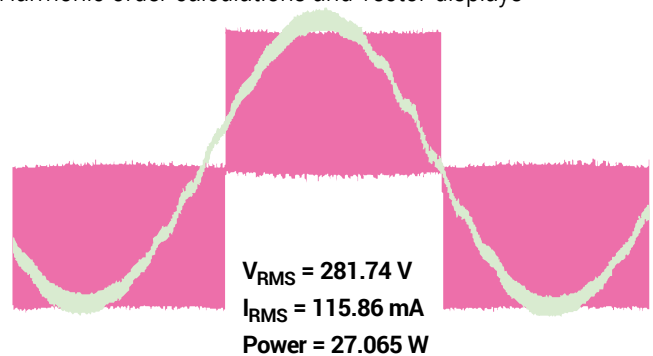

# Dynamic



## Capture More Information

- Long records for analysis (seconds to minutes of capture time)
- Per-cycle Waveforms reveal detailed dynamic behaviors
- Zoom+Gate easily localizes dynamic behaviors

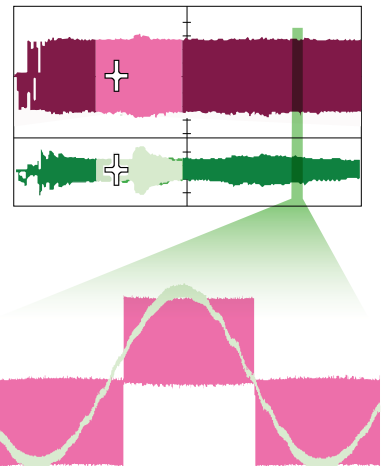

# Complete

## More Test Coverage

- Built on a high-bandwidth 12-bit oscilloscope platform
- Easily correlate control system, inverter subsection, and motor behaviors to a single switching cycle
- One instrument, one solution for motor drive engineers

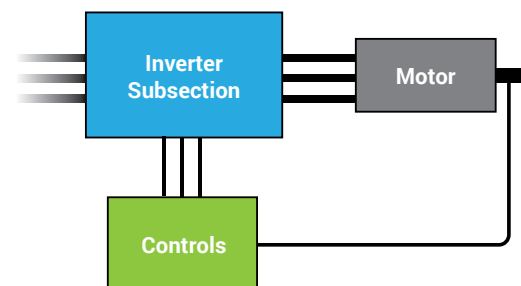



# What Motor Drive Engineers Need

- Acquire any signal for short or long durations - everything on one display
- Perform 3-phase electrical and mechanical power calculations at your bench
- Correlate complex power, control, and motor behaviors

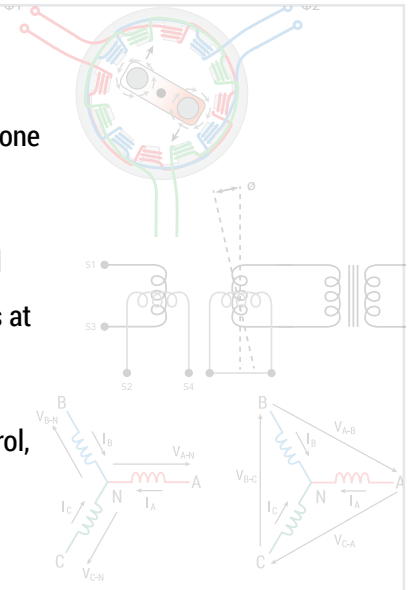

## 3-Phase Electrical and Mechanical Power and Control Analysis



MDA 8000HD  
Motor Drive Analyzer

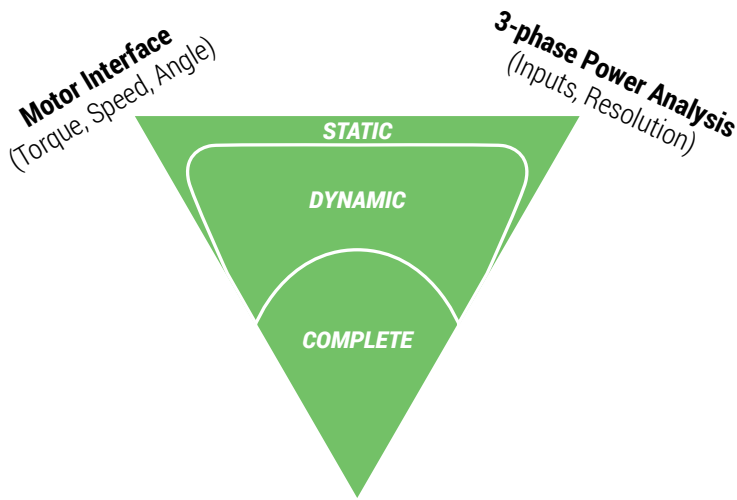

**Complete Acquisition Capabilities**  
(BW, SR, Resolution, Memory;  
Analog, Digital, Sensor, Serial Data)

**Motor drive engineers need to understand every part of drive system operation. They need to view control, sensor, device and power waveforms, they need to understand dynamic events, and they need flexibility to debug anything.**

**The Motor Drive Analyzer does it all.**

- Up to 2 GHz, 10 GS/s, 5 Gpts with 12-bit resolution
- Dynamic power analysis, from startup to overload
- Per-cycle time-correlated power Waveforms
- Comprehensive motor interface (Torque, Speed, Angle, Power)
- Unique Zoom+Gate mode
- Two- and three-wattmeter methods supported
- Harmonics calculations, displays and filtering (optional)
- Vector displays (optional)
- Up to 6000 Vrms isolation with HVD Series differential probes
- Easily interface many different current measurement devices

## Static power analysis

The mean-value Numerics table displays voltage, current, power, speed, torque, etc. values for short (or long) time periods during constant load, speed and torque operating conditions - just like what a dedicated power analyzer instrument provides.

## Dynamic power analysis

Capture thousands of power cycles over long time periods. Per-cycle Waveform displays help you understand dynamic behaviors. Use Zoom+Gate to isolate and correlate power behaviors to control system operation during dynamic load, speed and torque operating conditions.

## Complete test coverage

Acquire and display analog, digital, sensor and serial data signals from both power and embedded control systems. Correlate power system behaviors to control system activity during time periods as short as a single device switching cycle.

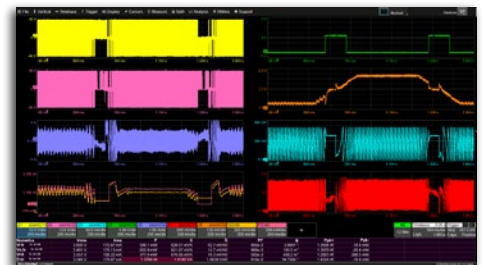
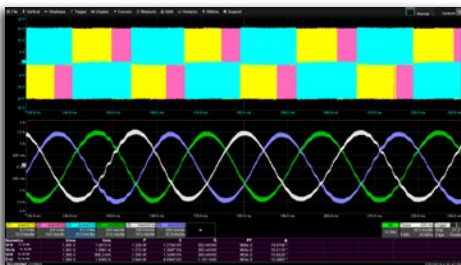

## Motor Drive Analyzer complete test coverage

The Motor Drive Analyzer acquires any analog, digital, sensor, serial data or power signal and performs three-phase electrical and mechanical power calculations. It has the flexibility to acquire and measure almost anything.

In contrast, single-function power analyzers only provide simple "black-box" numerical analysis during static operating conditions. Most oscilloscopes are good for basic embedded control debug and validation, but they lack enough inputs for complex drive system and control system analysis, and don't have enough resolution to precisely measure power and efficiency values.

### Typical Power Analyzer Test Coverage

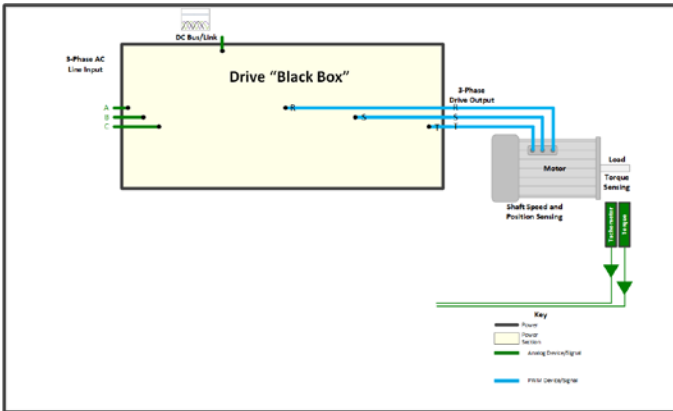

### Typical Oscilloscope Test Coverage

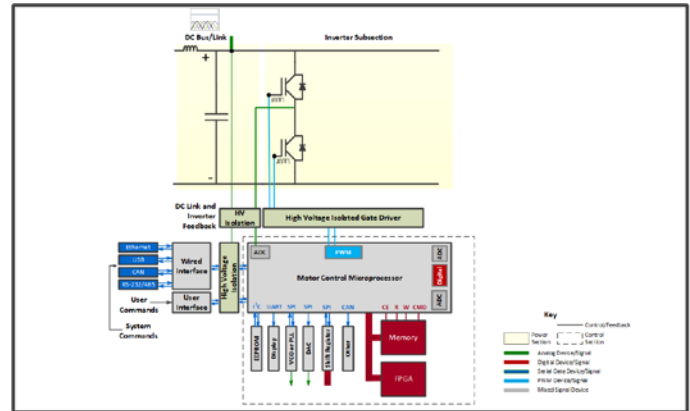

## Teledyne LeCroy Motor Drive Analyzer Test Coverage

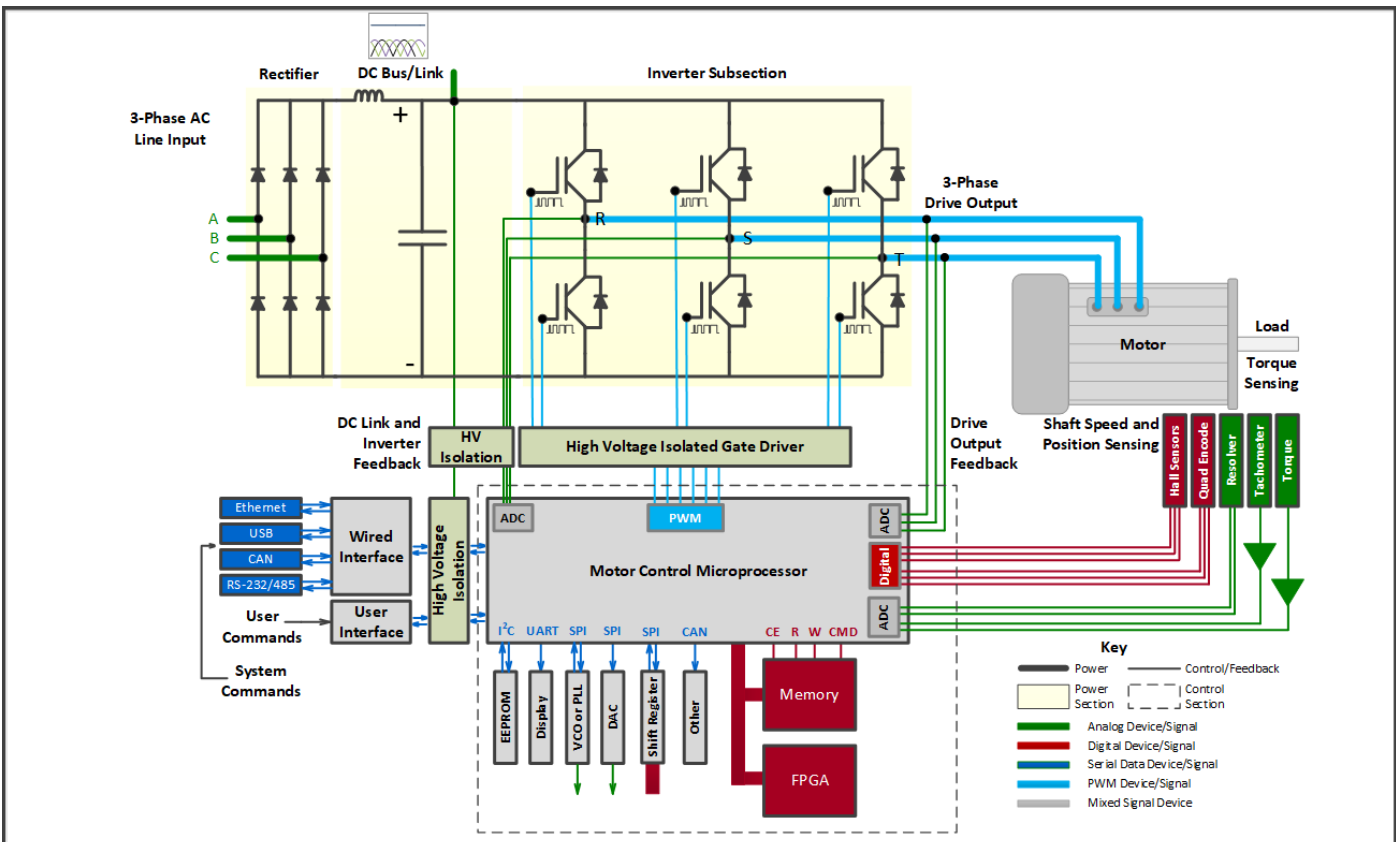

The Motor Drive Analyzer tells you more about your motor, drive and controls than anything else. It's what you wanted and didn't know to ask for.

### 1. Zoom+Gate Mode

Zoom in to gate the results to a region in a long acquisition. Updates instantly. See page 9.

### 2. Comprehensive Mechanical Interface

Supports nearly every sensor type. Derive speed/torque without sensors. See page 10.

### 3. Numerics Table

See the mean values for the entire acquisition in a user-defined table. See page 8.

### 4. Vertical Zooming

Capture details through independent vertical zoom of waveforms.

### 5. Precise Harmonic Filtering

Limit results to Fundamental only, Fundamental + N, or Range. (some optional).

### 6. Flexible, Intuitive, Graphical Setup

Gain confidence using a graphic interface with re-calculation upon setup changes.

### 7. Q-Scape Multi-tabbed Displays

Organize waveforms onto separate tabs, then view them all at once or one tab at a time.

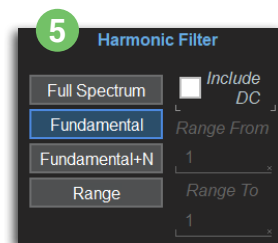
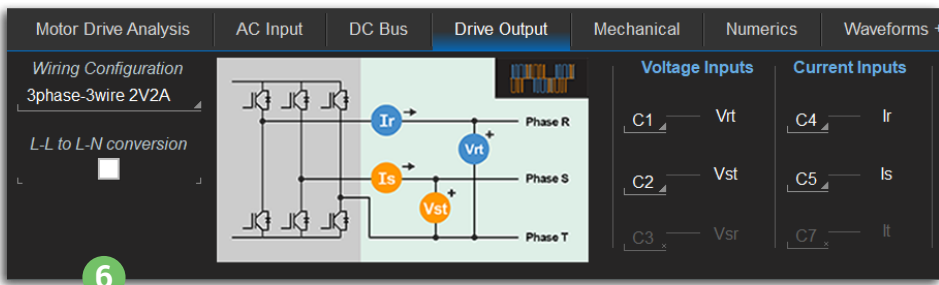



## 8. Multi-stage Efficiency Analysis

Calculate stage-stage and overall (cumulative) efficiency.

## 9. Connect Two MDAs (for 16 Channels)

Use OscilloSYNC™ to quickly connect two MDAs and create one 16-channel MDA.

## 10. Per-cycle Waveform Displays

Touch the Numerics table to create a plot of the measurement versus time.

## Cursors

Place a cursor on any waveform and get an instantaneous reading of drive behavior.

## Statistics Table

Displays complete statistical data for any Numerics table measurement.

## Vector Displays

View the 3-phase system through an intuitive, six vector display (optional). See page 8.

## Harmonic Calculations

Display harmonic values in a table, with spectral waveforms and THD per-cycle Waveforms (optional). See page 8.

## Real-time αβγ (Clarke) & dq0 (Park) Transformation

Convert and view 3-phase waveforms in αβγ or dq0 domains (optional). See page 8.

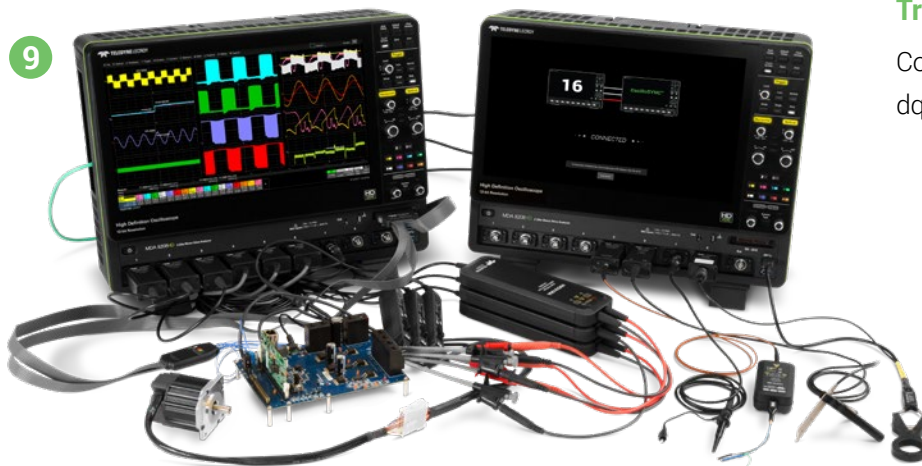

## Numerics Measurement Table

- User-configurable - up to 120 values in 10 (source) rows and 12 (measurement) columns.
- Mean value summaries of per-cycle calculations.
- Select for Full Spectrum or Fundamental Only calculations (other selections optional).

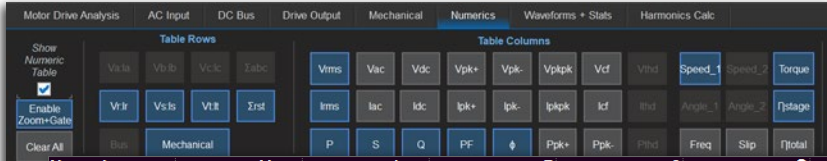

Numerics	Vrms	Irms	P	S	Q	PF	$\phi$	Torque	Speed1	$\eta$ stage
Vr:lr LL to LN	172.50 V	11.129 A	1.91165 kW	1.9199 kVA	151.90 VAR	996e-3	4.6064 °			
Vs:ls LL to LN	171.23 V	10.936 A	1.85947 kW	1.8728 kVA	205.34 VAR	993e-3	6.3630 °			
Vt:lt LL to LN	171.90 V	10.742 A	1.83789 kW	1.8466 kVA	157.03 VAR	995e-3	4.9469 °			
$\Sigma$ rst LL to LN	171.88 V	10.936 A	5.60901 kW	5.6394 kVA	522.69 VAR	994e-3	5.3864 °			
<b>Mechanical</b>			5.2267 kW					42.85 N m	1.164836 krpm	932.1e-3

Quickly select the measurement sources and types to display in a mean-value Numerics table.

## Vector Displays (Optional)

- Two simultaneous displays.
- Zoom+Gate and harmonically filter to show vector changes during dynamic events.

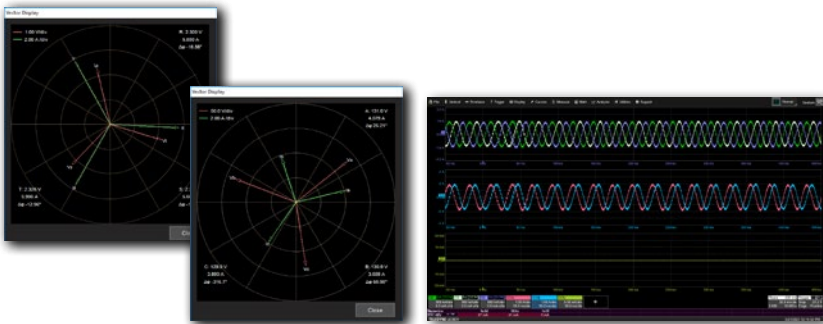

Display 2 simultaneous vector views of 3-phase power systems.

$\alpha\beta\gamma$  (Clarke) transformed waveforms

## Waveform Transformations (Optional)

- View two simultaneous  $\alpha\beta\gamma$  (Clarke) & dq0 (Park) real-time transformations.
- Integrated support for angle sensors allows adjustment to rotor field angle, and replicates control system's understanding of instantaneous motor torque and speed.

## Harmonics Calculations (Optional)

- Rigorous software DFT method precisely separates desired frequency content.
- Calculates AC line-side (fixed-frequency) or inverter/drive output (variable-frequency).
- Adds "Fundamental + N" and "Range" selections to Harmonic Filter settings.
- THD numeric calculation and per-cycle Waveforms.
- Harmonic order table and spectral displays (up to nine simultaneous).



Capture and calculate harmonics during very short or long acquisitions and show results as Spectral Waveform displays, total THD values or per-cycle THD Waveforms.



This simplified example shows THD for voltage and current (bottom magenta and orange Waveforms) plotted over time with one THD value per power cycle.

## Per-cycle Waveforms

- Displays measured behaviors as value vs. time Waveforms, with one value per measurement cycle.
- Simple setup – touch a Numerics table value and a per-cycle Waveform is displayed.
- Time-correlated to other acquired signals - measured anomalies or unexpected changes are quickly revealed.
- Display complete statistics of all values.



Capture voltage, current and other signals and calculate dynamic responses using per-cycle Waveforms to better understand complex drive, control and motor behaviors.

## Dynamic Drive Response

- Capable of thousands of dynamic power cycle measurements.
- Minutes of acquisition time (e.g., 2.5 GS of memory at 10 MS/s sample rate = over 4 minutes).
- Complete understanding of drive system behaviors – startup, load application/release, etc.
- Correlate drive response problems to control system instructions or power section failures.
- Use dq0 (Park) transformation to correlate power section behavior to control system activity.

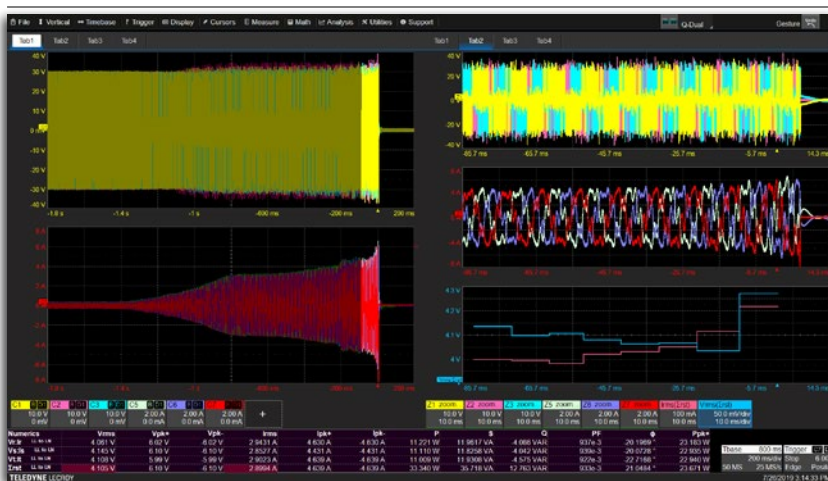

Take very long acquisitions, calculate values for the complete data set, then Zoom+Gate to get a Waveform and Numerics view of just the zoomed area.

## Zoom+Gate Mode

- One touch creates Zoom waveforms and “gates” the Numeric measurements to the zoomed area.
- Per-cycle Waveforms are time-correlated to Zooms for easy problem investigation.
- Change zoom location and all Numerics and Waveforms instantly update.
- Gain fast and deep insight into dynamic drive and control system behaviors.

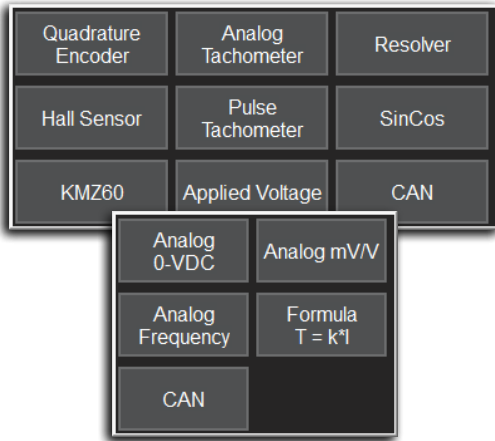

14 different methods to calculate speed, angle and torque - most supported only by the Motor Drive Analyzer.

## Unrivaled Speed and Torque Interface

- Nine speed, four angle and five torque calculations or sensors supported.
- Calculate mechanical power at your bench without external sensors connected.
- Infer torque from phase current measurement and torque constant.
- Infer speed from stator frequency.
- Angle Tracking Observer filter capability to emulate control system operation.
- Display calculated speed, torque and angle values as per-cycle Waveforms.



Speed data is extracted from digital CAN-encoded serial data and plotted as an analog speed per-cycle Waveform, as if the signal was directly probed.

## Digital Speed/Torque Sensor Support

- Quadrature encoder, BLDC Hall sensor and Pulse Tachometer support.
- Use digital inputs to capture digital sensor signals, preserving analog channels for other use.
- Extract speed and torque information from serial data signals (optional with serial data TDME packages).

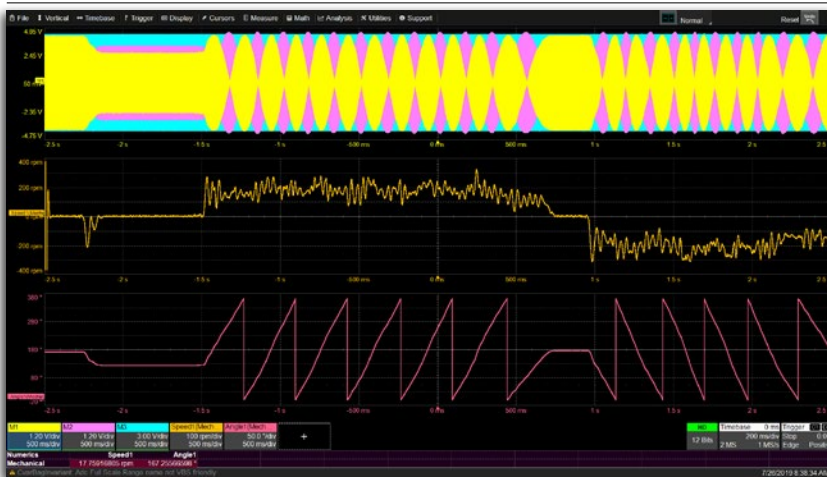

Speed and angle are calculated from the analog sine, cosine and excitation frequency signals of a resolver, with user-defined angle tracking observer applied.

## Complex Speed Sensor Support

- SinCos, Resolver and KMZ60 sensor support.
- Calculate instantaneous motor shaft angle values.
- Correct motor shaft angle to rotor magnetic field angle.
- Apply Angle Tracking Observer filter to better correlate to control system operation.
- Use instantaneous motor shaft angle to display dq0 (Park) transform to rotor reference frame.



Power is measured and shown as per-cycle Waveforms for each instantaneous device switching cycle to determine operation during rotor flux changing commands.

## Calculate Power During Very Short Durations

- Use short duration periods (e.g., device switching cycles, QEI pulse periods) for power calculations.
- Easily validate instantaneous drive system response time to control system changes (e.g., Vector FOC, DB-DTFC).
- Perform spectral analysis of calculated power, speed, torque, etc. values with high frequency resolution.



Drive control and feedback signals are compared to drive output voltage and current and calculated power Waveforms to understand whether motor reversal is performing correctly.

## Correlate Power Section and Control System Behaviors

- View analog, digital or serial data control signals time-correlated with power section behaviors.
- Compare control system calculated or measured response to actual drive and motor behaviors.
- Calculate and view power section behaviors as per-cycle Waveforms for a more intuitive understanding of flaws and defects.
- Use dq0 (Park) transformation to correlate power section behavior to control system activity.



Measured losses are compared to drive control system estimated losses and further calculations are made to separate measured losses into core (iron) and load (copper) losses.

## Complex Measurements and Math

- Perform real-time updated measurements on live acquisitions for faster debug and optimization.
- Calculate and plot losses from measured data and motor constants.
- Perform math on calculated numeric values using additional constants to derive additional results.
- Derive winding balance for complex systems.

## Setup Capability

Measurement Locations	AC Input, DC Bus (Link), Drive Output, Mechanical Output
Wiring Configurations	AC Input: 1-phase / 2-wire (1V1A); 1-phase / 3-wire (2V/2A); 3-phase / 3-wire (2V2A); 3-phase / 3-wire (3V3A); 3-phase / 4-wire (3V3A); None DC Bus: 1-phase / 2-wire (1V1A); None Drive Output: 1-phase / Half-Bridge (1V1A); 1-phase / Full-Bridge (1V1A); 3-phase / 3-wire (2V2A); 3-phase / 3-wire (3V3A); 3-phase / 4-wire (3V3A); None
Harmonic Filter	Select either Full Spectrum or Fundamental only. With WR8kHD-THREEPHASEHARMONICS option, also select Fundamental + N (harmonics) or Range (maximum 50th harmonic in both cases).
Sync (per-cycle) Measurement Signal	Independently settable for AC Input, DC Bus, Drive Output and Mechanical Output. Low pass filter (LPF) cutoff settable from 20 Hz to 1 MHz. Hysteresis settable from 0-100% full amplitude. Source can be any input analog channel, memory trace or math function.
Voltage Measurement Method	Line-Line or Line-Neutral (with L-L to L-N conversion supported)
Calculation Waveform Sources	Any input channel or stored memory trace

## Numerics Measurement Table Selections (calculated per cycle, mean value displayed)

Voltage	RMS voltage, AC Voltage, DC Voltage, Peak Positive Voltage, Peak Negative Voltage, Peak-Peak Voltage, Voltage Crest Factor, Voltage Total Harmonic Distortion (THD) (with the WR8kHD-THREEPHASEHARMONICS option)
Current	RMS Current, AC Current, DC Current, Peak Positive Current, Peak Negative Current, Peak-Peak Current, Current Crest Factor, Current Total Harmonic Distortion (THD) (with the WR8kHD-THREEPHASEHARMONICS option)
Power, Efficiency and Other	Real, Apparent and Reactive Power, Peak Positive Real Power, Peak Negative Real Power, Power Total Harmonic Distortion (THD) (with the WR8kHD-THREEPHASEHARMONICS option), Power Factor, Phase Angle, Incremental Efficiency, Total Efficiency, Frequency
Motor Mechanical	Torque, Speed1, Speed2, Angle1, Angle2 (as defined by sensor or adjusted with Offset Angle setting), Mechanical Power, AC induction motor Slip
$\alpha\beta\gamma$ (Clarke) & dq0 (Park) Transform	Voltage, Current (with the WR8kHD-THREEPHASEdq0 option)
Source Selections	Voltage: Va, Vb, Vc, Va-b, Vb-c, Vc-a, Vr, Vs, Vt, Vr-s, Vs-t, Vt-r, Ia, Ib, Ic, Ir, Is, It, Vbus, Ibus, Mechanical, ABCq $\beta$ , ABCdq0, RSTq $\beta$ , RSTdq0, RSTdq0rf. Up to 10 rows (sources) and 12 columns (measurements) may be displayed in the table at any time. Source selections dependent on Wiring Configuration selections and Line-Line to Line-Neutral selections.

## Per-cycle Waveforms and Statistics

Waveforms	A time-correlated waveform of any per-cycle Numerics Table measurement parameter may be created and displayed anywhere on the grid. Up to 12 detailed per-cycle Waveforms may be displayed at one time, with up to 40 waveforms total (channels, memories, zooms, math and per-cycle Waveforms) displayed at any one time.
Statistics	Detailed statistics on up to 12 per-cycle Numerics Table measurement parameters may be displayed at one time.

## Zoom+Gate Mode

Operation	Zoom+Gate creates zooms of all voltage, current and mechanical signals (analog or digital) and simultaneously gates the Numerics and Statistics tables to the zoomed area. Displayed per-cycle Waveforms are simultaneously time-correlated to the zoomed area. Scroll through the full acquisition using zoom position and ratio (size) controls and view instantaneous updates of table values.
-----------	---

## Motor Mechanical Interface

Speed + Direction	Analog Tachometer (0-x Vdc = Speed). Source is analog input. Digital Tachometer (x pulse/revolution = speed). Source may be digital or analog input. Applied Voltage. Source is one analog input. Controlled Area Network (CAN) Serial Data. Source is CAN message with embedded digital data. CANbus TD or TDME option must be ordered separately. Hall Sensors (three digital inputs). Source may be digital or analog input. Angle Tracking Observer filter may be applied to this selection.
Speed + Direction + Angle	Resolver. Source is three analog inputs. SinCos. Source is two analog inputs. KMZ60. Source is two analog inputs. Quadrature Encoder Interface (QEI) (A, B and optional Z input). Source may be digital or analog input. Angle Tracking Observer filter may be applied to all selections.
Torque	Analog 0-Vdc = Torque. Source is one analog input. Analog mV/V = Torque. Source is one analog input. Analog Frequency Modulated = Torque. Source is one analog input. Motor Constant K * Current = Torque. Source is MDA calculated per-cycle current value. Controlled Area Network (CAN) Serial Data = Torque. Source is CAN message with embedded digital data. CANbus TDME option must be ordered separately.

## Typical Accuracy

Voltage, Current and Power	Accuracy is typically within 1%, depending on voltage and current measurement device. Recommended voltage probe (line-line voltage sensing): Teledyne LeCroy HVD Series High Voltage Differential Probe (1 kV, 2 kV and 6 kV isolated models available). Recommended voltage probe (line-neutral or line-reference voltage sensing): Teledyne LeCroy HVD Series HV Differential Probe for voltages >50Vrms, Teledyne LeCroy passive probe (Qty. 4 included) for voltages $\leq$ 50 Vrms Recommended current probes: Teledyne LeCroy CP Series Current Probes. Other voltage and current measurement devices may be interfaced to the oscilloscope and analysis software using built-in rescaling and unit selection capabilities. The CA10 current sensor adapter provides programmability for rescaling and unit selection.
----------------------------	--

### Harmonics Calculation Option (part number WR8KHD-THREEPHASEHARMONICS)

Fundamental Frequency Detection	Fixed Frequency detection mode (for Line AC inputs only) or Varying Frequency detection mode (for Line AC inputs or Inverter PWM outputs).
Number of Harmonics Calculated	Up to 100 (Fixed Frequency) or up to 50 (Varying Frequency)
Harmonics Table and Spectral Waveform Display	Values by Harmonic Order for up to nine quantities (Voltage, Current and Power) for any or all of three phases (limited to Voltage and Current in Fixed Frequency mode).
Units/Limits Selection	Amps/Volts/Watts, % or dB. For Fixed Frequency, pre-defined limits file or custom limits file.

### Vector Display Option (part number WR8KHD-THREEPHASEVECTOR)

Number of Vector Displays	Two: one for AC Input and one for Drive Output
Vector Display Selection	Arithmetic or Vector Sum
Display Information	Volts, Amps and Phase Angle for each vector

### Waveform Transforms (part number WR8KHD-THREEPHASEdq0)

Transform Locations	AC Input, Drive Output
Transform Method	None, $\alpha\beta$ , dq0, dq0r
Calculation Waveform Sources	Any input channel or stored memory trace

### Other Available Options & Accessories

Acquisition Memory	Options available for up to 1.25 Gpts/Ch on all 8 channels (up to 5 Gpts/Ch interleaved)
OscilloSYNC™ Technology (16ch)	Combine two MDAs into a single, 16-channel acquisition system. OscilloSYNC option enables the display and control of 16 time-synchronized channels on one MDA after making a simple BNC and Ethernet connection between two instruments.
Mixed Signal Oscilloscope	WR8KHD-MSO: 16 digital input capability. Up to 500 MHz digital clock rate, flexible analog and digital cross-pattern trigger and use of digital logic lines for mechanical speed sensing and serial data clock, data and chip select probing. Optional serial data trigger and decode software available.
Serial Triggers, Decode, Measure/Graph and Eye Diagram	Optionally available: I2C, SPI, UART-RS232, CAN, CAN FD, LIN, FlexRay, ARINC429, Audio (I2S), DPHY, DigRF3G, DigRFv4, DPHY, ENET, I3C, Manchester, MDIO, MIL1553, NRZ, SENT, SpaceWire, SPMI, USB2, USB2-HSIC, and 8b/10b. Symbolic triggering and decoding is available for CAN and CAN FD. TDME options provide automatic serial message timing measurements, serial (digital) data extraction and conversion (D-A capability), and eye diagrams.
Probes and Accessories	A comprehensive list of voltage and current probes is supported on the Motor Drive Analyzer. Additionally, rack-mounts, carts, cases, additional removable drives, GPIB interface and CPU RAM upgrades are also available.
Other Application Software Packages	Power (Semiconductor Device and Switch-mode Power Supply) Analysis, Digital Filtering, Clock+Timing Jitter, Serial Data Jitter, Serial Data Compliance, Spectrum Analysis, EMC/EMI Measurements, and Developer's Toolkit.

Teledyne LeCroy offers 4- and 8-channel High Definition Oscilloscopes that support some of the same capabilities as the Motor Drive Analyzer when purchased with the THREEPHASEPOWER software option.

THREEPHASEPOWER on HDO6000B & WavePro HD	THREEPHASEPOWER on WaveRunner 8000HD	MDA 8000HD Motor Drive Analyzer
--	--------------------------------------	---------------------------------



Feature	HDO6000B & WavePro HD	WaveRunner 8000HD	MDA 8000HD
Analog Input Channels	4	8 (16 with OscilloSYNC)	8 (16 with OscilloSYNC)
Digital Input Channels	16 (on -MS models)	16 (with MSO option)	16 (with MSO option)
Resolution	12 bits	12 bits	12 bits
Bandwidth	350 MHz - 8 GHz	350 MHz - 2 GHz	350 MHz - 2 GHz
1-Phase Power Analysis	✓	✓	✓
3-Phase Power Analysis	✓ (2-wattmeter method only)	✓	✓
Mechanical Power Analysis	X	X	✓
X-Y Traces	X	X	✓
Harmonics Calc Option	✓	✓	✓
Vector Display Option	✓	✓	✓
Waveform Transformation Option	✓ ( $\alpha\beta$ & dq0 only)	✓ ( $\alpha\beta$ & dq0 only)	✓

**Product Description** **Product Code**

**MDA 8000HD Motor Drive Analyzers**

350 MHz, 8 Ch, 12 Bits, 10 GS/s, 50 Mpts/Ch  
Motor Drive Analyzer with 15.6" 1920x1080 capacitive touch screen and 4K extended desktop. Includes Motor Drive Analysis 3-phase electrical and mechanical power analysis software.

MDA 8038HD

500 MHz, 8 Ch, 12 Bits, 10 GS/s, 50 Mpts/Ch

MDA 8058HD

Motor Drive Analyzer with 15.6" 1920x1080 capacitive touch screen and 4K extended desktop. Includes Motor Drive Analysis 3-phase electrical and mechanical power analysis software.

1 GHz, 8 Ch, 12 Bits, 10 GS/s, 50 Mpts/Ch

MDA 8108HD

Motor Drive Analyzer with 15.6" 1920x1080 capacitive touch screen and 4K extended desktop. Includes Motor Drive Analysis 3-phase electrical and mechanical power analysis software.

2 GHz, 8 Ch, 12 Bits, 10 GS/s, 50 Mpts/Ch

MDA 8208HD

Motor Drive Analyzer with 15.6" 1920x1080 capacitive touch screen and 4K extended desktop. Includes Motor Drive Analysis 3-phase electrical and mechanical power analysis software.

**Included with Standard Configurations**

±10, 500 MHz passive probe (Qty. 4), protective cover, Getting Started Guide, Motor Drive Analysis Software Instruction Manual, Microsoft Windows® 10, commercial NIST traceable calibration with certificate, power cable for the destination country, 3-year warranty

**Motor Drive Analyzer Power Analysis Options**

3-phase Harmonics Calculation WR8KHD-THREEPHASEHARMONICS

Vector Analysis WR8KHD-THREEPHASEVECTOR

αβγ (Clarke) & dq0 (Park) Waveform Transform WR8KHD-THREEPHASEdq0

**Memory Upgrade Options**

500 Mpt/2Ch (250 Mpt/4Ch, 125 Mpt/8Ch) WR8KHD-500MPT

1 Gpt/2Ch (500 Mpt/4Ch, 250 Mpt/8Ch) WR8KHD-1000MPT

2 Gpt/2Ch (1 Gpt/4Ch, 500 Mpt/8Ch) WR8KHD-2000MPT

5 Gpt/2Ch (2.5 Gpt/4Ch, 1.25 Gpt/8Ch) WR8KHD-5000MPT

**CPU, Computer and Other Hardware Options**

Additional Standard Solid State Drive WR8KHD-RSSD-02

16 GB to 32 GB CPU RAM Upgrade\* WR8KHD-UPG-32GBRAM

\* 32 GB RAM upgrade is included with all memory upgrade options.

**Oscilloscope Synchronization Options**

16-channel OscilloSYNC Software (combines two WaveRunner/MDA 8000HD oscilloscopes) WR8KHD-16CH-SYNCH

**Mixed Signal Solutions**

Mixed Signal Oscilloscope (incl. 16-channel digital leadset, 22 extra large gripper probes, 20 ground extenders, 5 flexible ground leads and license) WR8KHD-MSO

MSO License (without accessories) WR8KHD-MSO-LICENSE

**Product Description** **Product Code**

**Serial Trigger and Decode Options**

MIL-STD-1553 Trigger & Decode WR8KHD-1553 TD

MIL-STD-1553 Trigger, Decode, Measure/Graph & Eye Diagram WR8KHD-1553 TDME

8b10b Decode WR8KHD-8B10B D

ARINC 429 Symbolic Decode WR8KHD-ARINC429BUS D SYMBOLIC

ARINC 429 Symbolic Decode, Measure/Graph & Eye Diagram WR8KHD-ARINC429BUS DME SYMBOLIC

AudioBus Trigger & Decode WR8KHD-AUDIOBUS TD

AudioBus Trigger, Decode & Graph WR8KHD-AUDIOBUS TDG

CAN FD Trigger & Decode WR8KHD-CAN FDBUS TD

CAN FD Trigger, Decode, Measure/Graph & Eye Diagram WR8KHD-CAN FDBUS TDME

CAN FD Symbolic Trigger, Decode, Measure/Graph, & Eye Diagram WR8KHD-CAN FDBUS TDME SYMBOLIC

CAN Trigger & Decode WR8KHD-CANBUS TD

CAN Trigger, Decode, Measure/Graph & Eye Diagram WR8KHD-CANBUS TDME

CAN Symbolic Trigger, Decode, Measure/Graph & Eye Diagram WR8KHD-CANBUS TDME SYMBOLIC

DigRF 3G Decode WR8KHD-DIGRF3GBUS D

DigRF V4 Decode WR8KHD-DIGRFV4BUS D

MIPI D-PHY CSI-2 & DSI Decode WR8KHD-DPHYBUS D

Embedded Bundle: I2C, SPI, UART-RS232 Trigger & Decode WR8KHD-EMB TD

Embedded Bundle: I2C, SPI, UART-RS232 Trigger, Decode, Measure/Graph, & Eye Diagram WR8KHD-EMB TDME

ENET Decode WR8KHD-ENETBUS D

FlexRay Trigger & Decode WR8KHD-FLEXRAYBUS TD

FlexRay Trigger, Decode, Measure/Graph & Physical Layer Tests WR8KHD-FLEXRAYBUS TDMP

I2C Trigger & Decode WR8KHD-I2CBUS TD

I2C Trigger, Decode, Measure/Graph & Eye Diagram WR8KHD-I2CBUS TDME

I3C Trigger & Decode WR8KHD-I3CBUS TD

I3C Trigger, Decode, Measure/Graph & Eye Diagram WR8KHD-I3CBUS TDME

LIN Trigger & Decode WR8KHD-LINBUS TD

LIN Trigger, Decode, Measure/Graph & Eye Diagram WR8KHD-LINBUS TDME

Manchester Decode WR8KHD-MANCHESTERBUS D

MDIO Decode WR8KHD-MDIOBUS D

NRZ Decode WR8KHD-NRZBUS D

SENT Trigger & Decode WR8KHD-SENTBUS TD

SENT Trigger, Decode, Measure/Graph & Eye Diagram WR8KHD-SENTBUS TDME

SpaceWire Decode WR8KHD-SPACEWIREBUS D

SPI Trigger & Decode WR8KHD-SPIBUS TD

SPI Trigger, Decode, Measure/Graph & Eye Diagram WR8KHD-SPIBUS TDME

SPMI Trigger & Decode WR8KHD-SPMIBUS TD

SPMI Trigger, Decode, Measure/Graph & Eye Diagram WR8KHD-SPMIBUS TDME

UART-RS232 Trigger & Decode WR8KHD-UART-RS232BUS TD

UART-RS232 Trigger, Decode, Measure/Graph & Eye Diagram WR8KHD-UART-RS232BUS TDME

USB 2.0 Trigger & Decode WR8KHD-USB2BUS TD

USB 2.0 Trigger, Decode, Measure/Graph & Eye Diagram WR8KHD-USB2BUS TDME

USB 2.0 HSIC Decode WR8vKHD-USB2-HSICBUS D

Product Description	Product Code
<b>Serial Data Compliance Test Options</b>	
QualiPHY 1000Base-T1 Compliance Software	QPHY-1000BASE-T1*
QualiPHY BroadR-Reach Software	QPHY-BROADR-REACH*
QualiPHY Ethernet 10/100/1000BT Software	QPHY-ENET*
QualiPHY MOST150 Software	QPHY-MOST150
QualiPHY MOST50 Software	QPHY-MOST50
QualiPHY USB 2.0 Software	QPHY-USB†
10/100/1000Base-T Ethernet Test Fixture	TF-ENET-B**
USB 2.0 Compliance Test Fixture	TF-USB-B

\* TF-ENET-B required † TF-USB-B required  
 \*\* Includes ENET-2CAB-SMA018 and ENET-2ADA-BNC SMA

<b>Debug Toolkit Options</b>	
100Base-T1 and 1000Base-T1 Debug Toolkit	WR8KHD-AUTO-ENET-TOOLKIT
Automotive Ethernet Breakout Test Fixture for 100Base-T1 and 1000Base-T1 Debug Toolkit	TF-AUTO-ENET

<b>Serial Data Analysis Options</b>	
Serial Data Analysis Software (single-lane eye, jitter and noise measurements)	WR8KHD-SDAIII
Eye Doctor II Software (channel & fixture de-embedding/emulation, Tx/Rx equalization)	WR8KHD-EYEDRII
Virtual Probe Software (advanced de-embedding, emulation and virtual probing)	WR8KHD-VIRTUALPROBE
Serial Data Mask Software	WR8KHD-SDM
Cable De-Embedding Software	WR8KHD-CBL-DE-EMBED

<b>Power Analysis Options</b>	
Power Analyzer Software	WR8KHD-PWR
Digital Power Management Analysis	WR8KHD-DIG-PWR-MGMT

<b>Jitter Analysis Options</b>	
JitKit Software (clock/clock-data jitter analysis with statistical, spectral and jitter overlay)	WR8KHD-JITKIT

<b>Digital Filtering Options</b>	
Digital Filter Software	WR8KHD-DFP2

<b>Other Software Options</b>	
EMC Pulse Parameter	WR8KHD-EMC
Spectrum Analyzer and Advanced FFT	WR8KHD-SPECTRUM
VectorLinQ Vector Signal Analysis	WR8KHD-VECTORLINQ
Advanced Customization	WR8KHD-XDEV

<b>Remote Control/Network Options</b>	
External USB2 to GPIB Adaptor	USB2-GPIB

<b>General Accessories</b>	
MDA 8000HD Rackmount Kit	WR8KHD-RACKMOUNT
Instrument Cart (with additional shelf and drawer)	OC1024-A

Product Description	Product Code
<b>Probes</b>	
Power/Voltage Rail Probe with 4 GHz bandwidth, 1.2x attenuation, $\pm 30$ V offset, $\pm 800$ mV	RP4030
High Voltage Fiber Optic Probe, 60 MHz bandwidth	HVFO103
500 MHz Passive Probe, 2.5mm, 10:1, 10 M $\Omega$	PP021
500 MHz Passive Probe, 5mm, 10:1, 10 M $\Omega$	PP025
1 GHz, 0.9 pF, 1 M $\Omega$ High Impedance Active Probe	ZS1000
Set of 4 ZS1000 Active Probes	ZS1000-QUADPAK
1.5 GHz, 0.9 pF, 1 M $\Omega$ High Impedance Active Probe	ZS1500
Set of 4 ZS1500 Active Probes	ZS1500-QUADPAK
200 MHz, 3.5 pF, 1 M $\Omega$ Active Differential Probe, $\pm 20$ V	ZD200
500 MHz, 1.0 pF Active Differential Probe, $\pm 8$ V	ZD500
1 GHz, 1.0 pF Active Differential Probe, $\pm 8$ V	ZD1000
1.5 GHz, 1.0 pF Active Differential Probe, $\pm 8$ V	ZD1500
500 MHz, Active Differential Probe ( $\div 1$ , $\div 10$ , $\div 100$ )	AP033
30 A, 10 MHz Current Probe - AC/DC, 30 Arms, 50 A peak pulse, 3-meter cable	CP030-3M
30 A, 50 MHz Current Probe - AC/DC, 30 Arms, 50 A peak pulse, 1.5-meter cable	CP030
30 A, 50 MHz High Sensitivity Current Probe - AC/DC, 30 Arms, 50 A peak pulse, 1.5-meter cable	CP030A
30 A, 100 MHz Current Probe - AC/DC, 30 Arms, 50 A peak pulse, 1.5-meter cable	CP031
30A, 100 MHz High Sensitivity Current Probe - AC/DC, 30 Arms, 50 A peak pulse, 1.5-meter cable	CP031A
150 A, 10 MHz Current Probe - AC/DC, 150 Arms; 500 A peak pulse, 2-meter cable	CP150
150 A, 5 MHz Current Probe - AC/DC, 150 Arms, 500 A peak pulse, 6-meter cable	CP150-6M
500 A, 2 MHz Current Probe - AC/DC, 500 Arms, 700 A peak pulse, 6-meter cable	CP500
Deskew Calibration Source	DCS025
Programmable Current Sensor to ProBus Adapter (for third-party current sensors)	CA10
Set of 4 CA10 Programmable Current Sensor to ProBus Adapters (for third-party current sensors)	CA10-QUADPAK
100:1 400 MHz 50 M $\Omega$ 1 kV High-Voltage Probe	HVP120
100:1 400 MHz 50 M $\Omega$ 4 kV High-Voltage Probe	PPE4KV
1000:1 400 MHz 50 M $\Omega$ 5 kV High-Voltage Probe	PPE5KV
1000:1 400 MHz 5 M $\Omega$ / 50 M $\Omega$ 6 kV High-Voltage Probe	PPE6KV
TekProbe to ProBus Probe Adapter	TPA10
Optical-to-Electrical Converter, 500-870 nm ProBus BNC Connector	OE425
Optical-to-Electrical Converter, 950-1630 nm ProBus BNC Connector	OE455
1 kV, 25 MHz High Voltage Differential Probe	HVD3102A
1 kV, 25 MHz High Voltage Differential Probe (without tip accessories)	HVD3102A-NOACC
1 kV, 120 MHz High Voltage Differential Probe	HVD3106A
1 kV, 120 MHz High Voltage Differential Probe (without tip accessories)	HVD3106A-NOACC
1 kV, 80 MHz High Voltage Differential Probe - 6-meter Cable and Auto Zero Disconnect	HVD3106A-6M
2 kV, 120 MHz High Voltage Differential Probe	HVD3206A
2 kV, 80 MHz High Voltage Differential Probe - 6-meter Cable and Auto Zero Disconnect	HVD3206A-6M
6 kV, 100 MHz High Voltage Differential Probe	HVD3605A
700 V, 25 MHz High-Voltage Differential Probe ( $\div 10$ , $\div 100$ )	AP031
7.5 GHz Low Capacitance Passive Probe ( $\div 10$ , 1 k $\Omega$ ; $\pm 20$ , 500 $\Omega$ )	PP066

# DONHO

唐和股份有限公司

台北總公司 台北市內湖區瑞光路618號8F  
TEL:02-2627-1088 FAX:02-2627-7369  
台中分公司 台中市西屯區朝富路213號22樓-2  
TEL:04-2252-5037 FAX:04-2252-5057  
高雄分公司 高雄市楠梓區德民路220號  
TEL:07-365-1388 FAX:07-365-1399  
[www.donho.com.tw](http://www.donho.com.tw)  
FLIR授權經銷商 HIOK台灣總代理

## Customer Service

Teledyne LeCroy oscilloscopes and probes are designed, built, and tested to ensure high reliability. In the unlikely event you experience difficulties, our digital oscilloscopes are fully warranted for three years and our probes are warranted for one year.

This warranty includes:

- No charge for return shipping
- Long-term 7-year support
- Upgrade to latest software at no charge



1-800-5-LeCroy  
[teledynelecroy.com](http://teledynelecroy.com)

Local sales offices are located throughout the world.  
Visit our website to find the most convenient location.